

WeIVac 200/210 Vacuum Manifold

For rapid, parallel processing of nucleic acids
with vacuum assisted elution

A. Introduction

The WelVac 200 Vacuum Manifold is designed for the rapid preparation of plasmid DNA, single-stranded phage DNA, RNA, genomic DNA, viral nucleic acids, DNA cleanup from PCR and other enzymatic reactions. For most protocols, the WelVac 200 eliminates the need for time-consuming pipetting and centrifugation. The manifold reduces sample handling to a minimum by allowing direct parallel and simultaneous processing of up to 24 mini columns, 8 midi or maxi columns, and 96-well plates.

In addition, WelVac 200 Vacuum Manifold eliminates the need for separate manifolds, with the new vacuum manifold and column adaptor board. This vacuum system allows a single vacuum manifold to serve as a purification platform for either 96-well plates or individual luer-ended columns. It is especially ideal for those laboratories requiring saving time and space.

B. Important Notice

1. Please discard the packing materials according to your local environmental protection policy.
2. This vacuum manifold is designed for non-corrosive filtration. Any corrosive reagent could damage the instrument and shorten its usage life.
3. Please use a properly grounded electrical outlet of correct voltage and current handling capacity to avoid a fire disaster or the risk of electric shock.
4. Do not use it near flammable or combustible materials avoid a fire disaster or explosion. The instrument contains the components of these materials may ignite.
5. The instrument shall not be modified or altered in any way. Any modification or alteration will void the warranty and the regulatory certifications and even create the potential security problems. We are irresponsible for any injury or damage caused by using the instrument for any non-intended purpose or modifying the instrument by any person who is not authorized.
6. Please cut off power supply before maintenance and repairs by qualified service personnel.

C. Unpacking and checking

Before unpacking this instrument, please check the packing case is complete without any damage. After unpacking, please check the accessories are complete as list. If there is something missing, please immediately reserve the serial number, packing case, and contact your local distributor to claim support.

D. Packing List

WelVac 200

WelVac 200 Vacuum Manifold	x1
Spare O-ring	x1
Spare gasket	x1
Allen wrench	x1
Column adaptor board	x1
Luer connector	x25
Luer stopper	x25
Waste tray	x1
Instruction Manual	x1

WelVac 210

WelVac 200 Vacuum manifold	x1
Rocker 300 Vacuum Pump	x1
Silicon tube	x1
Spare O-ring	x1
Spare gasket	x1
Allen wrench	x1
Column adaptor board	x1
Luer connector	x25
Luer stopper	x25
Waste tray	x1
Instruction Manual	x1

E. Over View

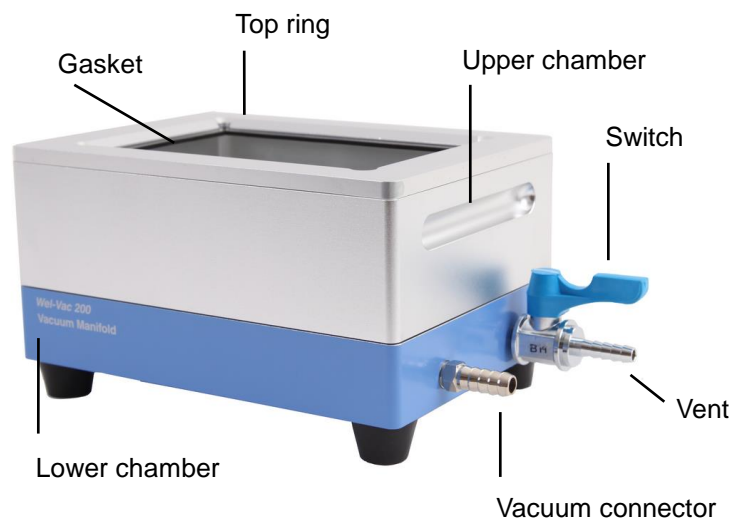

<Fig. 1> WelVac 200 Vacuum Manifold Over View



A. 96-well plate

B. 24 mini spin columns

C. 8 maxi spin columns

<Fig. 2> Application of WelVac 200 Vacuum Manifold

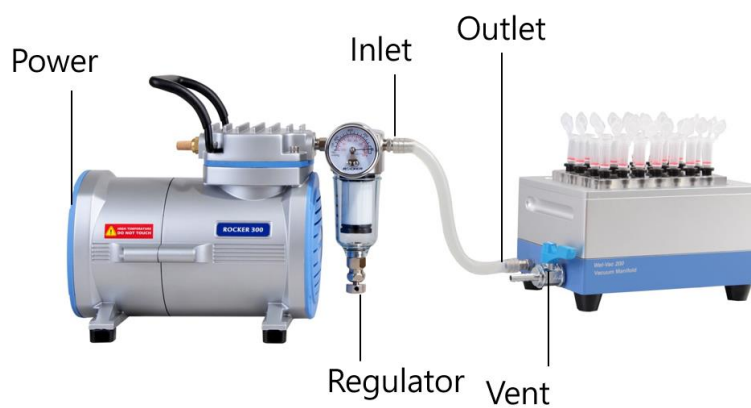

<Fig. 3> WelVac 210 Vacuum Manifold Over View

F. Part View

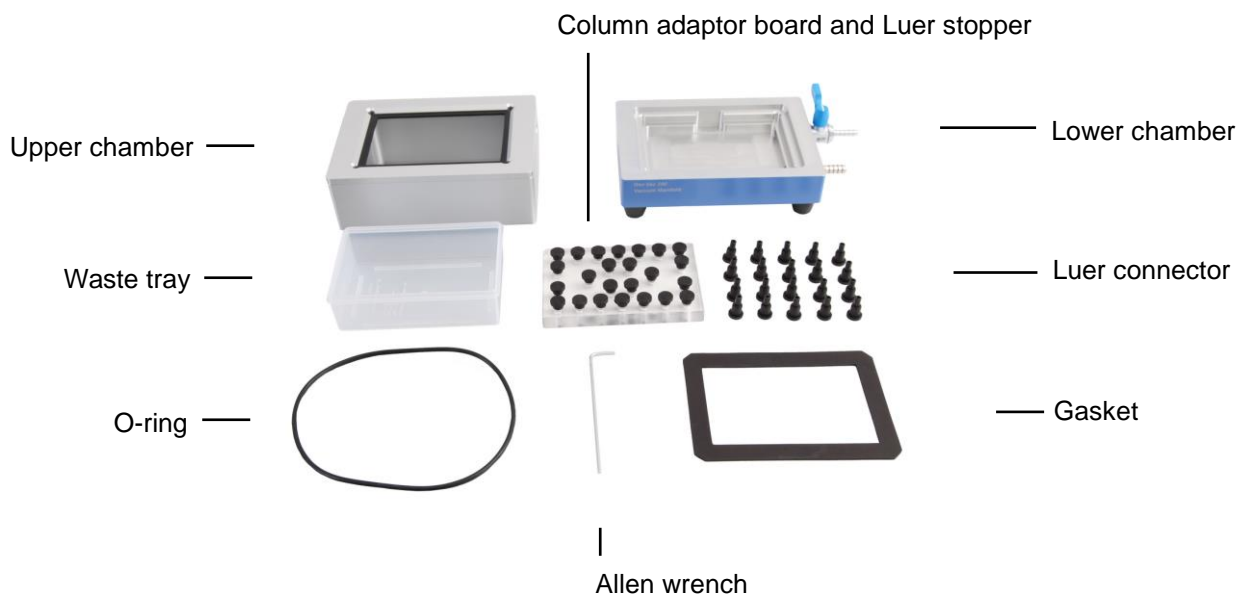

<Fig. 4> WelVac 200 Vacuum Manifold Part View

G. Installation

WelVac 200

1. Ensure that all surfaces of contact part such as O-ring or gasket is free from dirt or debris.

Note: If the O-ring or the gasket is not clean, it would lead a poor airtight.

2. Put a waste tray (or receiver) in the lower chamber, then put the upper chamber on the top of the lower chamber. **(See Fig. 1)**
3. Select 96-well filter plate or column adaptor board and put on the gasket.
(See Fig. 2)

WelVac 210

1. Before using the vacuum pump, please confirm the voltage marked on the label is consistent with the local electricity.
2. Please set the pump on a clean, dust-less, ventilated and ambient temperature below 40°C workspace.
3. Connect outlet of WelVac 200 and inlet of Rocker 300 vacuum pump with silicon tube. **(See Fig. 3)**
4. Now, the manifold is assembled already.

H. Operation

- I. **Set the vacuum manifold to a desired vacuum before filtration.**

Important Notice:

Appropriate vacuum degree is a key point to get efficient extraction. We suggest setting the system of the vacuum degree in your protocol before filtration.

1. Close the vent on the WelVac 200 **(See Fig. 1)** and put column adaptor board with Luer stopper on the gasket of the upper chamber. **(See Fig. 2)**
2. Set the vacuum regulator (anticlockwise) to open position and turn on the vacuum pump.
(See Fig. 3)
3. Adjust the vacuum regulator (clockwise) to the desired setting of vacuum degree then turn off the vacuum pump. **(See Fig. 3)**

Note: Push the adaptor board lightly to ensure the manifold sealed when adjusting.

4. Open the vent on the WelVac 200 to release preassure, remove the column adaptor board and then close the vent again.
5. Now, the vacuum manifold is set up and ready to use.

Note: WelVac 200 also can be connected to local stationary vacuum source with optional vacuum regulator (Optional, 167301-06) to adjust vacuum degree.

II. 96-well plates extraction

1. Remove the upper chamber and put a waste tray into the lower chamber.
2. Replace the upper chamber and put the filter plate on the gasket.

Note: Please ensure that the gasket is clean, and the vent is on the off position.

(see Fig. 1)

3. When ready to extract, please turn on the vacuum pump power switch and press lightly on the filter plate to engage the vacuum seal.

Note: Make sure that the filter plate fits tightly on the gasket of the WelVac 200.

4. The manifold is now ready for filter plate processing according to the vacuum protocol of the appropriate purification kit.

Note: If you need to regulate the vacuum pressure, please adjust the regulator.

5. When finished, please turn off the vacuum pump power switch and open the vent to release the residual vacuum pressure to avoid the potential of filtrate sprayed out. (cross-contamination)

Note: Do not release the pressure by opening the corner of the filter plate to prevent deformation of the manifold gasket.

Note: You can also tap the top of the filter plate prior to remove residual droplets in the bottom of the tube.

6. Remove the filter plate and put it aside for further processing or dispose of it properly.
7. Remove the upper chamber and the waste tray and utilize the waste for further processing.
8. After finished, please rinse the WelVac 200 vacuum manifold with water and either air dry or wipe with paper towels.

Note: Failure to rinse the vacuum manifold at the end of each use will cause it becomes cloudy and pitted.

Note: Please avoid using organic solvent to clean.

III. Spin columns extraction

1. Remove the upper chamber and put a waste tray into the lower chamber.
2. Replace the upper chamber and put the column adaptor board on the gasket.

Note: Please ensure that the gasket is clean, and the vent is on the off position.

(see Fig. 1)

3. Insert the spin columns firmly into the Luer connectors, place them into the holes on the column adaptor board and then insert the Luer stoppers into other unused one. **(see Fig. 4)**

Note: Confirm the same type columns to avoid the different flow rates and ensure the stable filtration rate.

4. When ready to extract, please turn on the vacuum pump power switch and press lightly on the column adaptor board to engage the vacuum seal.

Note: Make sure that the column adaptor board fits tightly on the gasket of the WelVac 200.

5. The manifold is now ready for column processing according to the vacuum protocol of the appropriate purification kit.

Note: If you need to regulate the vacuum pressure, please adjust the regulator.

6. When finished, please turn off the vacuum pump power switch and open the vent to release the residual vacuum pressure to avoid the potential of filtrate sprayed out. (cross-contamination)

Note: Do not release the pressure by opening the corner of the column adaptor board to prevent deformation of the manifold gasket.

Note: You can also tap the top of the column adaptor board prior to remove residual droplets in the bottom of the tube.

7. Remove the column adaptor board and put it aside for further processing or dispose of the spin columns properly.

8. Remove the upper chamber and the waste tray and then utilize the waste for further processing.

9. After finished, please rinse the WelVac 200 vacuum manifold with water and either air dry or wipe with paper towels.

Note: Failure to rinse the vacuum manifold at the end of each use will cause it to be cloudy and pitted.

Note: Please avoid using organic solvent to clean.

IV. Replace the O-ring

When O-ring aged and vacuum can't be achieved, replacing a new one.

1. Remove existing O-ring from the bottom of the upper chamber. **(see Fig. 5)**

2. Ensure that the new O-ring is free from dirt, debris, and particulate matter.

3. Replace the new O-ring.

Note: When change O-ring, gasket should be replaced at the same time.

V. Replace the Gasket

When Gasket aged and vacuum can't be achieved, replacing a new one.

1. Remove the 12 screws located on the bottom portion of the upper chamber by Allen wrench.

(see Fig. 5)

2. Separate the top ring from the upper chamber.

3. Remove the old gasket and then clean the top ring groove.

4. Put the new gasket into the groove and put back the top ring.

Note: Ensure that the bottom of the top ring groove is aligned cover gasket.

5. Replace the 12 screws and tighten the four corner screws lightly and then lock all other screws.

Note: Do not lock too tight to avoid the top ring distortion and lead a pool airtight.

Note: When change gasket, O-ring should be replaced at the same time.

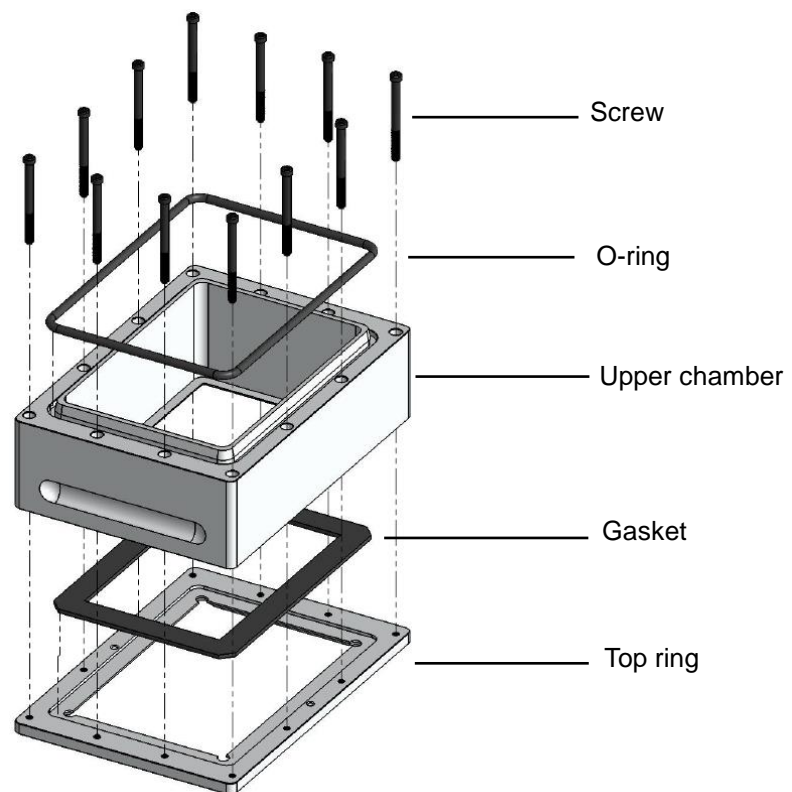

<Fig. 5> The assembly drawing of replace Gasket or O-ring

I. Maintaining

1. Please do the cleaning after each use to remove salts and buffer.

Note: Do not use any solvents include bleach or abrasives.

2. If the gasket, O-ring are aged or damaged, please replace it.

Note: Do not smear any silicone oil or vacuum grease to the gaskets or other parts of the WelVac 200 vacuum manifold.

3. Prohibiting contact with any strong chemical reagents to avoid the damage of the WelVac 200 Vacuum Manifold.

J. Troubleshooting

Possible cause	suggestions
Poor airtight	<ol style="list-style-type: none">1. Confirmed the O-ring and gasket are clean or has been damaged.2. Close the vacuum regulator. (clockwise)3. Close the vent.4. Check the tightness of the Luer connector or Luer stopper.5. Ensure all unused Luer connectors are replaced by Luer stoppers.6. Ensure uniform contact between upper chamber and low chamber.7. Press lightly on the filter plate or column adaptor board to engage the vacuum seal.8. Check the filter plates or column adaptor board for cracks.9. Ensure the vacuum connector and silicone tube are not loose or damaged.
Vacuum pump is too weak	<ol style="list-style-type: none">1. Replace a new vacuum source or wait for some time to generate sufficient vacuum pressure.

K. Ordering Information

195210-11 WelVac 210, Microplate Vacuum Manifold System, AC110V, 60Hz

195210-22 WelVac 210, Microplate Vacuum Manifold System, AC220V, 50Hz

195200-00 WelVac 200 Microplate Vacuum Manifold

167300-11 Vacuum pump Rocker 300, AC110V, 60Hz.

167300-22 Vacuum pump Rocker 300, AC220V, 50Hz.

195200-34 Silicone tube (30cm)

195200-35 Allen wrench

167301-06 Vacuum regulator

195200-42 Spin column adaptor board (24 hole), Acrylic

195200-43 Luer connector (25/PK)

195200-44 Luer stopper (25/PK)

195200-45 Waste tray

195200-46 Spin column adaptor board (24 hole), Polycarbonate

195200-60 Sealing kit (includes O-ring, gasket each one)