

INSTRUCTION MANUAL

Vacuum Controller

Model No.

Pilot 100



Video List

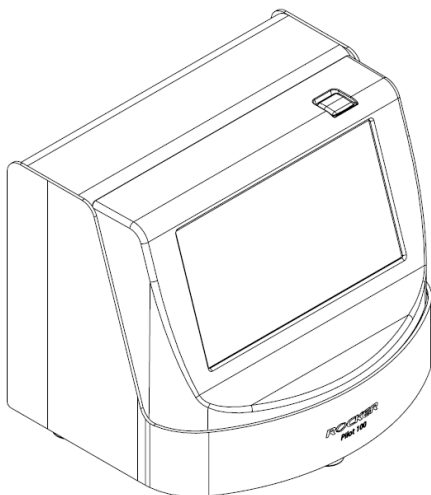

ROCKER

Please read this instruction manual before using this product.

Table of Contents

1. Important Notice	1
2. Unpacking	2
3. Product Description	3
(1) Control Station	3
(2) Control Panel	3
4. Installation and Connection	4
(1) Installation of Control Panel	4
(2) Wireless Connection of Control Station and Control Panel	5
(3) Tube Connection	5
(4) Example of Use – Rotary Evaporator	
5. User Interface	6
(1) Main Screen and Operating Elements	6
1.1 Main Screen	6
1.2 Operating Elements, Buttons and Icons	7
(2) Other Screens	9
2.1 Parameter List	9
2.2 Setting	10
2.2.1 Operating	10
2.2.2 Basic	10
2.3 Calibration	11
2.4 Buttons and Icons	11

6. Operation	12
(1) Touch Screen	12
(2) Program Operation	12
2.1 Vacuum Control – Pre-defined Program	12
2.2 Add A New Program and Set Parameters	13
2.3 Automatic Mode – Pre-defined Program	15
(3) Adjust Setpoint Pressure	16
3.1 Area for Adjusting Setpoint Pressure	16
3.2 Method for Adjusting Setpoint Pressure	16
(4) Venting	16
(5) Pressure Calibration	17
5.1 Tube Connection	17
5.2 Pressure Sensor Calibration	18
7. Maintenance	19
8. Troubleshooting	19
(1) Error / Warning Message	19
1.1 Error Messages	20
1.2. Error Log	20
1.3 Error Indication	20
(2) Troubleshooting	21

1. Important Notice

This instrument is designed for laboratory usage only. Please read this manual carefully before installing and operating. The instrument shall not be modified in any way. Any modification will void the warranty and may result in potential hazard. We are not responsible for any injury or damage caused by any non-intended purposes and modifying the instrument without authorization.

1. Check the voltage specified on the name plate and ensure it matches the line voltage in your location.
2. Install the instrument in a clean, dust-less and ventilated area under 40°C.
3. Never use the vacuum system with any flammable, explosive gas or toxic material.
4. Please connect the vacuum system with high-pressure hose or tubes.
5. If there is condensate or blockage in vacuum line, it may cause incorrect measurement of pressure sensor (or vacuum sensor).
6. Venting is introducing air into the evacuated system and can cause danger, e.g. explosive mixture, depending on applications. Be aware of risks during venting.
7. After finishing the experiment, please keep the pump on. While switch off the panel, it opens the valves according to the set parameter to pump the air and withdraw the residual steam.
8. If the instrument is damaged, e.g., supply cord, please contact the manufacturer or your service agent for replacement to avoid hazard.
9. After disconnecting the power supply, residual energy at plug might be danger. Please be aware of risks during cleaning and maintenance.
10. Before operation, please check the compatibility and interactions of materials of wetted parts with used medium.
11. Please discard packing material according to local related regulations. Please remove batteries before discarding.

- 12. Operating condition
 - (a) Ambient temperature: 5~ 40°C
 - (b) Relative humidity: 80% RH Max.
 - (c) Power supply: 100-240V~, 50/60Hz, 15W
 - (d) Altitude: up to 2000 m
 - (e) Pollution degree: II
 - (f) Indoor use



The equipment must be disconnected from the main supply before replacing the fuse.

2. Unpacking

Please check if the package is complete without any damage before unpacking. When unpacking, please make sure you have all accessories that indicated on the list. If there is any problem, please keep the serial number along with packing case and contact your local distributor immediately for assistance.

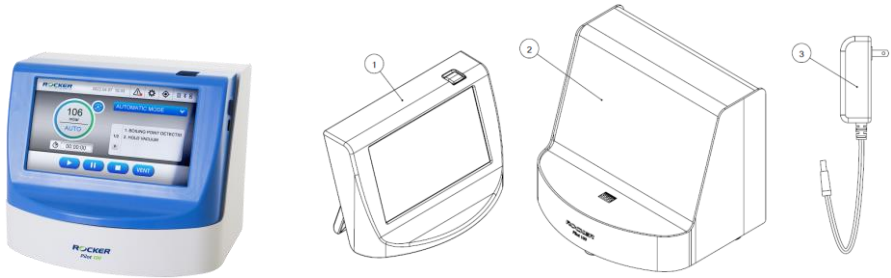

Pilot 100

Model	Standard Package Includes:
Pilot 100	1. Control Panel
	2. Control Station (Main Unit)
	3. Power Adaptor 24V1A
	4. Instruction Manual

3. Product Description

(1). Control Station

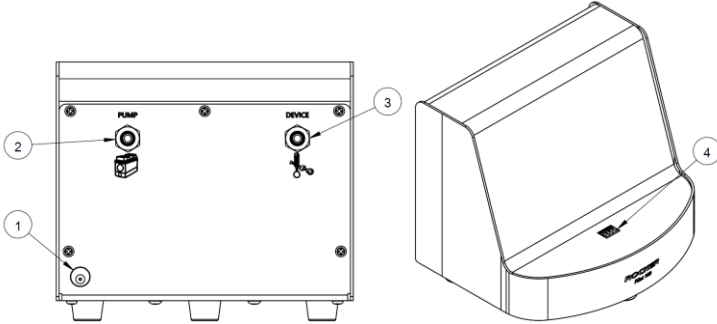

Position	Designation	Position	Designation
1	DC Socket	3	Hose Barb (To Evacuated System)
2	Hose Barb (To Vacuum Pump)	4	Charging Pole Piece

(2). Control Panel

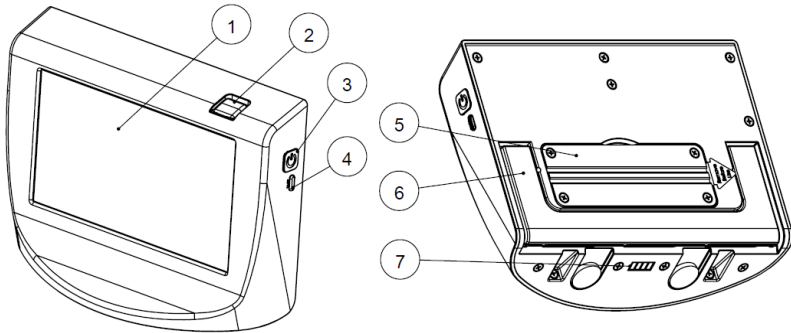

Position	Designation	Position	Designation
1	Touch Screen	5	Battery Cover *
2	Cover of SD Card Slot	6	Stand, foldable
3	ON/OFF Button	7	Charging Pole Piece
4	USB Type-C Charging Port (5V1A)		

* 18650 rechargeable battery is NOT included.

4. Installation and Connection

(1). Installation of Control Panel

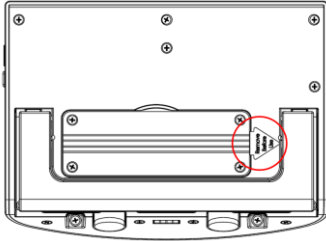

Remove the Insulation Tab

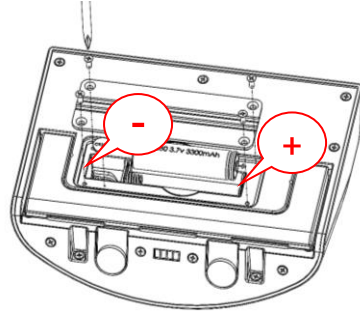

Positive / Negative of Battery

- ◆ If the battery is attached, please remove the battery insulation tab for initial operation.
- ◆ The panel could operate approx. 6 hours while installing an 18650 battery (3350mAh).
- ◆ Please purchase CR 1220 button cell battery when it needs to be replaced.

(A) Loosen the screws of battery cover by Phillips screwdriver and open the battery cover.

(B) Install the 18650 rechargeable battery, please connect electrodes correctly.

(C) Reattach the battery cover on control panel.

(2). Wireless Connection of Control Station and Control Panel

(A) Attach or near the control panel to control station which is connected to power source.

(B) Press and hold the ON/OFF button for 5 seconds to start up the control panel.

(C) Control station and control panel connect successfully if a blue Bluetooth icon  shows on the top right of screen.

(D) If the Bluetooth icon is grey , tap the Setting  icon on the top right of the screen.

(E) Tap the "START" button of Bluetooth Search in Operating tab to pair the control station.
Repeat the step until Bluetooth connection is successful.

- ◆ Control station starts pairing with control panel and back to main screen.

(F) Attach the control panel to power supplied control station to charge or connect a Type-C cable to USB Type-C charging port of the control panel to charge.

(3). Tube Connection

(A) Connect the hose barb marked PUMP to vacuum pump.

(B) Connect the hose barb marked DEVICE to evacuated system.

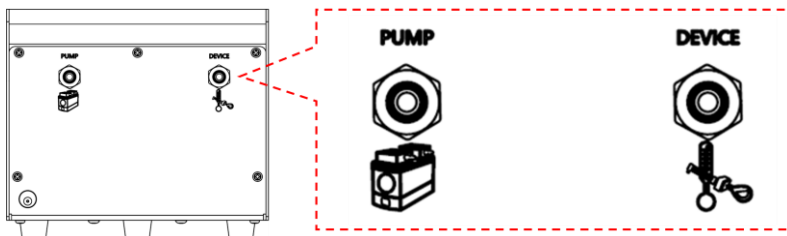

(4). Example of Use – Rotary Evaporator

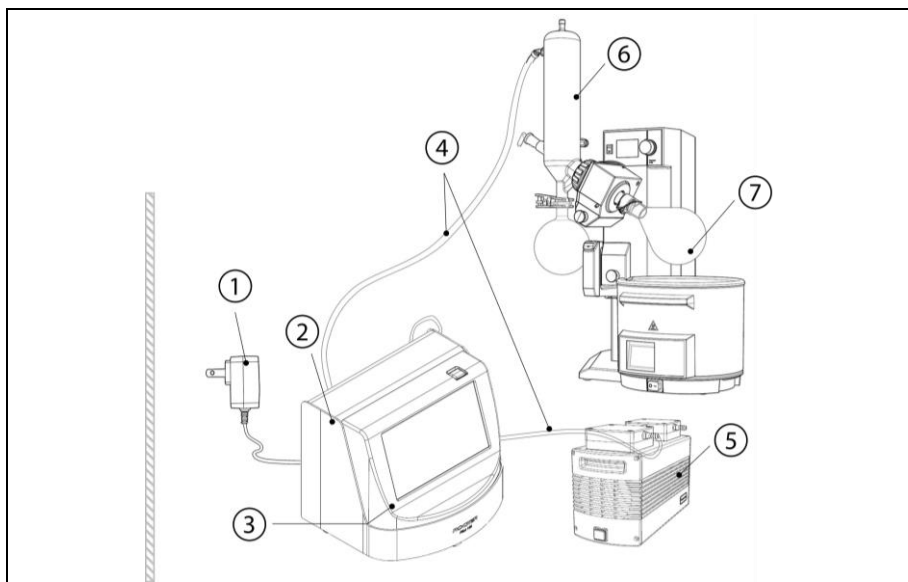

Position	Designation	Position	Designation
1	Power Adaptor	5	Vacuum Pump
2	Control Station	6	Example - Emission Condenser
3	Control Panel (Wireless Control)	7	Example – Rotary Evaporator
4	High-pressure Tube		

5. User Interface

(1). Main Screen and Operating Elements

Press and hold the ON/OFF button for 5 seconds to start up the control panel and make sure the control station and control panel are successfully connected. Instruction of connection, see P.4 (2) Connection of Control Station and Control Panel.

1.1 Main Screen

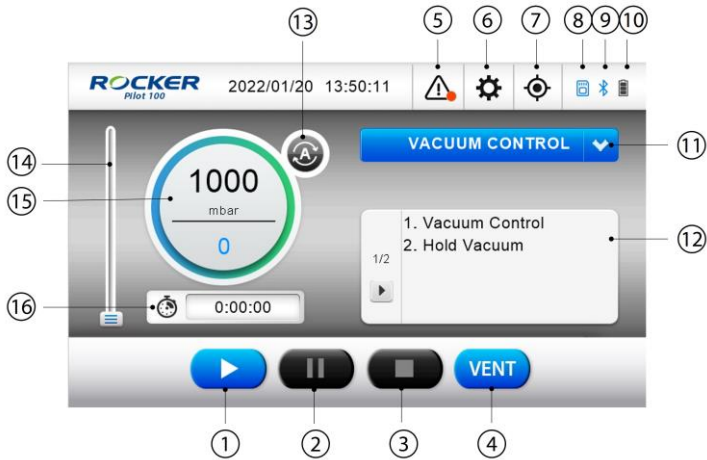

	Position	Function	Description
Control Zone	1	Start	Start the current program.
	2	Pause	Suspend the ongoing program.
	3	Stop	Stop, abandon the ongoing program.
	4	VENT	Vent the air into evacuated system.
Function Zone	5	Error Log	Warning and error message.
	6	Setting	Basic and operating parameters setting.
	7	Calibration	Calibrate the pressure sensor.
	8	SD Card	SD card inserted or not. (Blue: inserted)
	9	Bluetooth	Bluetooth connection state. (Blue: connection)
	10	Battery Level	Battery level and state. (Blue: charging)







	Position	Function	Description
Operation Zone	11	Program List	Program name, tap to show the program list
	12	Process Display	Overview of process steps, tap to open the Parameter List.
	13	Automatic Mode	Automatic Mode switching on / off.
	14	Pressure Display	Pressure display.
	15	Pressure Sliders	Swipe to adjust the pressure setpoint. Only available while pressure is adjustable.
	16	Process Time	Total process time (hh:mm:ss)

1.2 Operating Elements, Buttons and Icons





• Pressure Display

Position	Symbol	Description
14		<ul style="list-style-type: none"> • Pressure Blue: Setpoint pressure, motor speed (%) Black: Actual pressure * Pressure unit can be changed on Setting page * Blue item changes according to setting item.







• Buttons

Position	Active	Inactive	Description
1			<ul style="list-style-type: none"> • Start Start the current program.
2			<ul style="list-style-type: none"> • Pause Suspend the ongoing program.
3			<ul style="list-style-type: none"> • Stop Stop, abandon the ongoing program.

• Buttons (continued)

Position	Buttons		説明
4		Short Vent	<ul style="list-style-type: none"> • VENT Vent the air into evacuated system. <ul style="list-style-type: none"> ◆ Press button < 3 sec: short vent and program continues. ◆ Hold button > 3 sec.: vent to atmosphere and program suspends.
		Vent to Atmosphere	
13		Automatic Mode	<ul style="list-style-type: none"> • Automatic Mode Switch to Automatic Mode or Other programs.
		Other Programs	

• Icons

Position	Icons		Description
8		SD Card Inserted	<ul style="list-style-type: none"> • SD Card Inserted or not Used for software updates.
		No SD Card	
9		Connection	<ul style="list-style-type: none"> • Bluetooth Connection Check the connection state of vacuum pump and control panel.
		Failed Connection	
10		Charging	<ul style="list-style-type: none"> • Battery Level and Charging Current battery level and charging state. Battery level and state. (Blue: charging)
		Battery Level	

(2). Other Screens

2.1 Parameter List

Display and modify the steps and detailed parameters of the program. Each program is preset with 2 steps, and up to 10 steps can be included in a program.

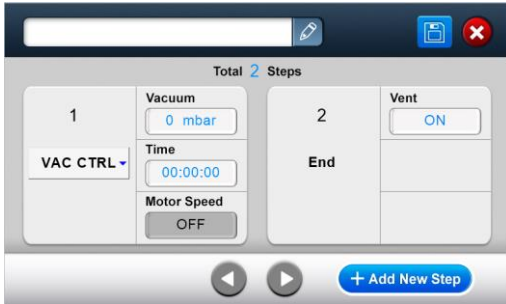

Parameter List

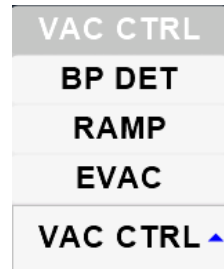

Drop-down Menu - 4 Steps

Steps can be selected from drop-down menu, the steps include

- **Vacuum Control (VAC CTRL):** maintains a setpoint pressure for a set period.
- **Evacuate (EVAC):** evacuate for a set period but enter to next step if setpoint pressure reaches.
- **RAMP (RAMP):** start from current pressure to reach a setpoint pressure with a set period by fixed slope.
- **Boiling Pressure Detection (BP DET):** same as Automatic Mode, enable detection boiling point (bp) pressure automatically and maintain the bp pressure for a set period.
- ◆ Item with underline is the set parameters of the step.
- ◆ If time is set as 00:00:00 (hh:mm:ss), it stands for infinite process.
- ◆ Time period of RAMP cannot be set to 00:00:00 (hh:mm:ss), otherwise it will be considered as infinite vacuum control.

2.2 Setting

Tap the setting button  on the main screen to enter the setting page. Setting page is divided into Operating and Basic by tabs

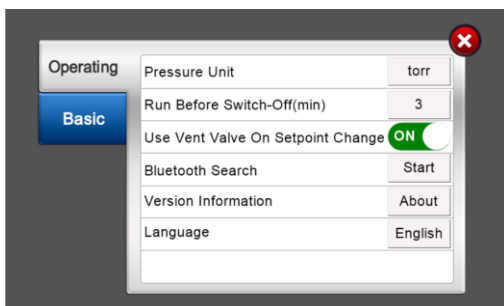

2.2.1 Operating Setting

- **Pressure Unit:** mbar, hPa, torr.
- **Run Before Switch-Off (min):** a self-clean mechanism, the valves open for a set period after switching off the control panel. To remove the solvent residues and increase the service life of instrument, please do NOT switch off the pump until cleaning is complete.
- **Use Vent Valve on Setpoint Change:** whether the system use the vent valve to adjust the pressure during operation. This setting is NOT applied to manual VENT on the main screen.
- **Bluetooth Search:** Bluetooth connection, see P.4 (2) Wireless Connection of Control Station and Control Panel.
- **Version Information**
- **Language:** English, Chinese.

2.2.2 Basic Setting







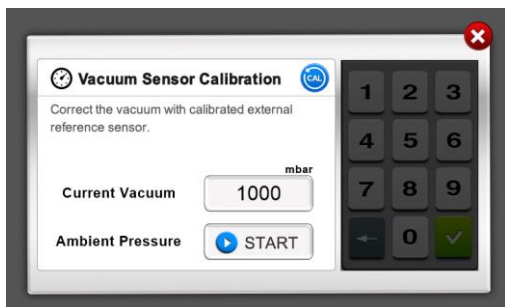





- **Display Brightness:** 20% / 40% / 60% / 80% / 100%.
- **Energy Saving Mode:** the screen will dim after 1 minute of standby, tap to wake it.
- **Button Tone:** ON / OFF.
- **Error Tone:** ON / OFF.
- **Date:** YYYY / MM / DD.
- **Time:** hh:mm:ss, 24-hour clock.
- **Factory Default Setting**

2.3 Calibration

Tap the calibration button  on the main screen to calibrate the pressure sensor.





2.4 Buttons and Icons

Buttons	Description
	• Cancel entry and modifications. Exit the window and back to previous page.
	• Confirm entry and modifications. Save setting and back to previous page.
	• Delete the entry number or letter(s).
	• Save the modified parameters.
	• Save as a new program.
	• Delete the step or program.
	• Switch ON and OFF the set parameters.
	• Switch between the previous / next pages.
	• Reset the pressure sensor to factory defaults.
	• Execute the pressure sensor calibration.
	• Modify the program name.
	• Add a new step.

6. Operation

(1). Touch Screen

The system is operated via touch screen. You can select and activated the function by tapping operation elements, buttons, etc.

Symbols	Gesture	Applied to
	Tap	Most buttons, such as start, stop, pause, process display, Automatic Mode, etc.
	Press and hold	VENT
	Swipe up and down	Pressure Sliders



(2) Program Operation

Pilot 100 vacuum controller has built in pre-defined program or can add a new program according to applications. Please ensure the tube connection and wireless connection are ready, see P.4 (2) Wireless Connection of Control Station and Control Panel and (3) Tube Connection.

- (Pre-defined) 2.1 Vacuum Control: See P.12.
- (Self-built) 2.2 Add A New Program: See P.13.
- (Pre-defined) 2.3 Automatic Mode: See P.15.

2.1 Vacuum Control – Pre-defined Program

Maintain a setpoint pressure until stop the program.

- (A) Select the “Vacuum Control” from program list.
- (B) Tap “Pressure Display Element” to input the setpoint pressure; or roughly regulate by swiping the pressure sliders.
- ◆ See P.16 (3) Adjust Setpoint Pressure.
- (C) Tap  to start the vacuum control program.
- ◆ The setpoint pressure is adjustable during operation.
- (D) Tap  or  to pause or stop the vacuum control program.



2.1.(A) Program List – Vacuum Control



2.1.(B) Adjust Setpoint Pressure



2.1.(C) Start Vacuum Control

2.2 Add A New Program and Set Parameters

Build customized program according to application, each program can have up to 10 steps.

(A) Select the “Add A New Program” from program list.

- ◆ Program list shows name of current program, tap to select programs or build a new one.

(B) Set the “step” and “target parameters” in screen of Parameter List.

- ◆ Step is selected from drop-down menu. The 4 built-in steps and definition, please see P.9 (2).2.1 Parameter List.
- ◆ See P.16 (3) Adjust Setpoint Pressure.



(C) Tap  to add a new step between existing 2 steps.

- ◆ Tap  to delete the step.
- ◆ The “End” step is used to determine the state of program end.
 - Vent ON: vent to atmosphere; Vent OFF: Keep the system closed with existing pressure.

(D) Tap  to save the new-built program and input the program name.

- ◆ Tap  to edit and modify the program name.

(E) Tap  to start the self-built program.

(F) Tap  or  to pause or stop the self-built program.

(G) Tap the “Process Display” to view or modify the parameters of saved program.

- ◆ The number on the left of process display stands for current step / total number of step. Tap arrow to skip and enter to next step.



2.2.(A) Program List – Add A New Program

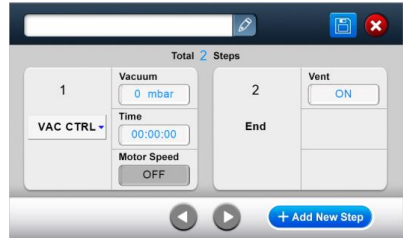

2.2.(B) Parameter List – Step and Parameters



2.2.(C) Parameter List – Add New Step

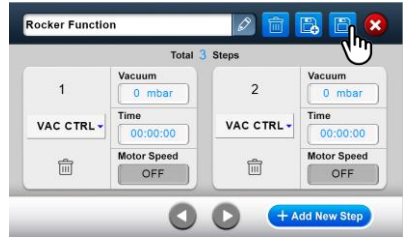

2.2.(D) Save The Program











2.2.(E) Start Self-built Program



2.2.(G) Parameters Modification

2.3 Automatic Mode – Pre-defined Program

When evaporation and distillation of unknown solvents, the boiling point pressure can be automatically detected by selecting the Automatic Mode.

- (A) Select the  Automatic Mode in Main Screen. You are in Automatic Mode if the  is blue and Program List shows Automatic Mode.
- ◆ The only way to exit the Automatic Mode is to tap the blue  and turns it into grey , then you can select the other programs from Program List.
- (B) Tap  to start the Automatic Mode. While boiling point pressure is detected, the AUTO shows pressure simultaneously and hold the pressure throughout the process.
- (C) Tap  or  to pause or stop the Automatic Mode. The pressure is vented to atmospheric pressure while end of the Automatic Mode.
- (D) Tap  to exit the Automatic Mode, then other programs can be selected.



2.3.(A) Automatic Mode



2.3.(B) Boiling Point Pressure Detection



2.3.(C) Stop Automatic Program



2.3.(D) Exit Automatic Mode

(3). Adjust Setpoint Pressure

Pilot 100 vacuum controller offers various options for adjusting the setpoint pressure which is adjustable during operation.

- ◆ The setpoint pressure cannot be adjusted from the main screen if setpoint pressure changes during steps. Please adjust the setpoint or parameters by taping Process Display.

3.1 Area for Adjusting Setpoint Pressure



Main Screen – Pressure Display or Sliders

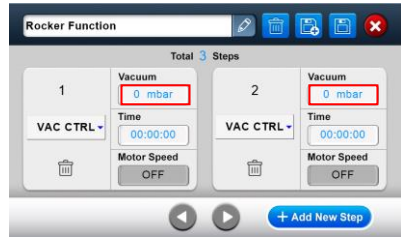

Parameter List – Vacuum Box

3.2 Method for Adjusting Setpoint Pressure



Keypad



Pressure Sliders

(4). Venting

Pilot 100 vacuum controller can vent the air into the evacuated system manually to regulate the pressure or prevent the bumping.

- ◆ Venting is introducing air into the evacuated system and can cause danger depending on applications, e.g. explosive mixture. Be aware of risks during venting.

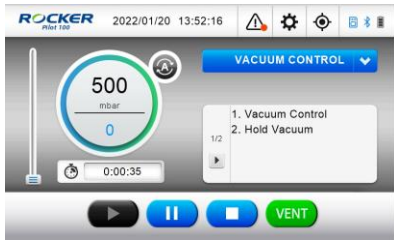

Briefly Press Button for < 3 Second
Short vent and program continues.



Hold Button for > 3 Second, VENT is Green
Vent to atmosphere and program suspends.

(5). Pressure Calibration

Calibration is to correct the internal pressure sensor by an external reference sensor, please calibrate system with a calibrated reference sensor to ensure the accuracy.

- ◆ If there is condensate or blockage in vacuum line, it may cause incorrect measurement of pressure sensor (or vacuum sensor).

5.1 Tube Connection

(A) Connect the hose barb marked PUMP to vacuum pump.

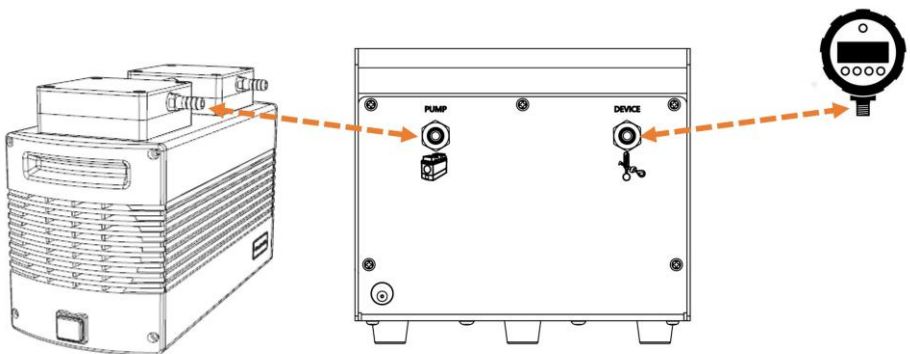

(B) Connect the hose barb marked DEVICE to the absolute pressure gauge.



5.2 Pressure Sensor Calibration

(A) Tap the  Calibration Button on the upper right of the main screen to enter the calibration page.

- ◆ Current Vacuum shows the present pressure of the pressure sensor.

(B) Tap  to release pressure automatically and detect current pressure .

(C) After detection, please input the reading of absolute pressure. Tap Confirm  to complete the ambient pressure calibration and followed by second point calibration.

(D) The 2nd point - High Pressure calibration starts and continues until pressure is stable.

(E) After detection, please input the reading of absolute pressure. Tap confirm  to complete the calibration process.

- ◆ After calibration is complete, it returns to main screen and vents to atmosphere.

(F) Tap  to reset the pressure sensor to factory defaults if necessary.



5.2.(A) Main Screen - Calibration

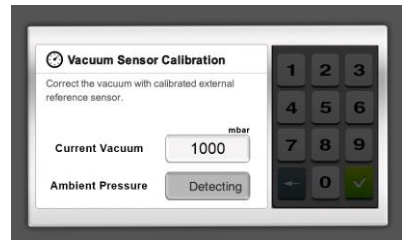

5.2.(B) Ambient Pressure Calibration

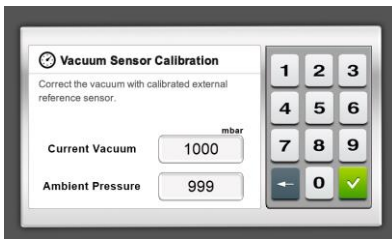

5.2.(C) Input Reading and Confirm

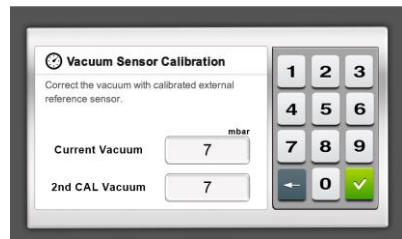

5.2.(E) High Pressure Calibration

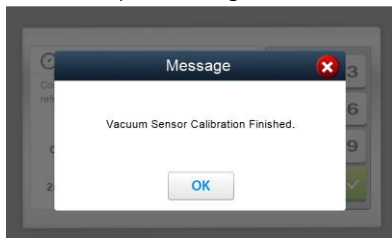

5.2.(E) Calibration Complete

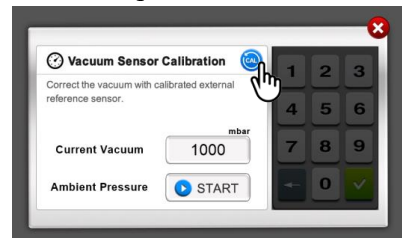

5.2.(F) Reset Calibration to Factory Defaults

7. Maintenance

1. Please operate the instrument in a well-ventilated area and keep it clean.
 2. The instrument is not autoclavable. Please clean the surface by pure water or 75% ethanol.
 3. If there's any solution drop or splash to instrument, please switch off and unplug it immediately and clean the surface to prevent damage from penetration or corrosion.
 4. After finishing the experiment, please turn on the Self-Clean Mechanism (see P.10 (2).2.1 Operating Setting) and keep the pump on. While switch off the panel, the vacuum controller keeps the vacuum path open according to the set parameter. Self-Clean Mechanism is used to pump the air to withdraw the residual steam and prolong the life of instrument.
 5. O-ring(s), tubing, disc filter, etc. are consumables, it is recommended to replace it on a yearly basis or as needed to ensure good operation.
- ♦ *If machine is forced to switch on when liquid flow in, it might cause serious damage, such as electric shock, short circuit, burn out, etc.*

8. Troubleshooting

(1). Error / Warning Message

If error happens during operation, a pop-up window appears to indicate. The instrument will be paused or stopped depends on severity. The error indicates by its color and symbol:

Serious



Minor



1.1 Error Messages



A. Error Message



B. Error Log

(1) Type of Symbol ;(2) Error Code and Message

1.2. Error Log

Error messages can be checked by tapping  Error Log page on the main screen.

Red dot  stands for new messages.

1.3 Error Indication

Error Code & Description	Reason	Solution
e02 Vacuum Leak or Low Pump Flow Rate!	1. Air leakage.	Replace and tighten the tubing that possible leaks.
	2. Faulty venting valve.	Replace a new venting valve.
	3. Faulty vacuum sensor.	Replace a new vacuum sensor.
	4. Low flow rate of pump	Replace a pump with appropriate flow rate
e03 Bluetooth Disconnect!	1. Inactive vacuum pump.	Plug and switch on the pump.
	2. Exceeded distance of control panel and pump.	Shorten distance of panel and pump.
	3. Faulty Bluetooth module of control panel.	Replace a new board of control panel.
	4. Faulty Bluetooth module of main board.	Replace a new main board.
e04 Vacuum Sensor Fault!	1. Loose or faulty connector of vacuum sensor.	Re-plug or replace the connector.
	2. Defective vacuum sensor.	Replace a new vacuum sensor.

Error Code & Description	Reason	Solution
e05 Over Pressure!	1. Incorrect calibration.	Re-calibrate or reset calibration to factory defaults.
	2. Incorrect tube connection of PUMP and DEVICE.	Connect tube correctly, see P.5 (3)
	3. Faulty vacuum sensor.	Replace a new vacuum sensor.
e06 Battery Sensor Fault!	1. Faulty PCB parts of control panel.	Replace a new PCB of control panel.
e07 Vent Valve Fault!	1. Faulty venting valve.	Replace a new venting valve.
	2. Loose or faulty connecting wires of venting valve.	Reconnect or replace connecting wires of venting valve.

(2). Troubleshooting

Problem	Reason	Solution
Control Station - Fail to start	1. Loose plug.	Reconnect plug to socket firmly.
	2. Faulty power adaptor	Replace a new power adaptor.
	3. Faulty main board or display board.	Replace new main board or display board.
Control Panel - Abnormal display or Fail to start	1. No battery.	Install the specified battery.
	2. Dead battery.	Attach the panel to pump or connect a Type-C cable to charge.
	3. Faulty main board.	Replace a new main board.
Abnormal operation of touch screen	1. Incorrect, damaged, loose wirings.	Replace new wirings and connect it correctly.
	2. Faulty display.	Replace a new display.
	3. Faulty main board.	Replace a new main board.
No or low acoustic sound	1. Button Tone is OFF.	Set the Button Tone ON.
	2. Sticker is on buzzer.	Remove the sticker on the buzzer.
	3. Faulty main board.	Replace a new main board.

(2). Troubleshooting (continued)

Problem	Reason	Solution
Poor vacuum	1. Improperly pressure setting.	Reset the pressure properly.
	2. Leaking tubing.	Reinforce the leaking tubing.
	3. Inactive or faulty vacuum pump.	Active or change a vacuum pump.
	4. Faulty vacuum sensor.	Replace a new vacuum sensor.
	5. Faulty venting valve.	Replace a new venting valve.
	6. Faulty main board.	Replace a new main board.
Disconnected panel or parameters is not updated instantly	1. Faulty or crashed communication modules.	Reinstall the 18650 battery correctly.
	2. Incorrect programming version.	Programming the correct version.

- ◆ Above is the basic instruction of troubleshooting. For technical support, please contact your local distributor or Rocker for assistance.

9. Ordering Information

183100-01(02)	Pilot 100, Vacuum Controller, AC100-240V adaptor, US plug (EU plug)
183100-10	Control Panel of Pilot 100
169410-11(22)	Chemker 410, Chemical Resistant Vacuum Pump, AC110V, 60Hz (AC220V, 50Hz)
169610-11(22)	Chemker 610, Chemical Resistant Vacuum Pump, AC110V, 60Hz (AC220V, 50Hz)
167200-38	Silicone Tube, \varnothing 6 x 12 mm, 1 m
180300-68	Silicone Tube, \varnothing 8 x 14 mm, 2 m

Rocker Scientific Co., Ltd.

Tel: +886-2-26033311 Fax: +886-2-26036622

E-mail: export@rocker.com.tw <https://www.rocker.com.tw>