

INSTRUCTION MANUAL

Oil Free Vacuum Pump

Model No.

Rocker 300 / 300DC / 400 / 410

Rocker 900 / 901 / 910 / 911

Instruction Video

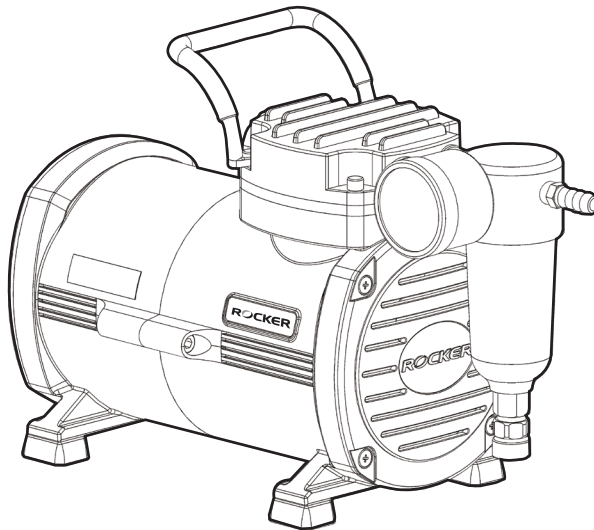

ROCKER

Please read this instruction manual before using this product.

Important Notice

This instrument is designed for laboratory usage only. Please read this manual carefully before installing and operating. The instrument shall not be modified in any way. Any modification will void the warranty and may result in potential hazard. We are not responsible for any injury or damage caused by any non-intended purposes and modifying the instrument without authorization.

1. Check the voltage specified on the name plate and ensure it matches the line voltage in your location.
2. Install the instrument in a clean, dust-less and ventilated area under 40°C.
3. Never use the pump with any corrosive, chemical, flammable gas or toxic material.
4. Please connect the pump with high-pressure hose or tubes.
5. The Prote™ filter cartridge can prevent a large amount of liquid from overflowing into the pump. Please ensure the liquid in the moisture trap not exceed safety level.
6. To ensure proper function of the Prote™ protection device, the pump must be installing on a flat level surface and should not be moved when operation. If the buoy closes during operation, it must be manually reset by uninstalling and reinstalling the filter cartridge.
7. The filter cartridge is used to absorb moisture and dust. Please replace the cartridge to maintain pumping efficiency when it becomes dirty or color-changing.
8. The pump is not designed to start against applied vacuum. To prevent damage, verify that the inlet of pump is at atmospheric pressure before each start. If necessary, the inlet can be vented to atmosphere by partially unscrewing the vacuum regulator knob.
9. This pump has a thermal protection device that automatically shuts-off when it becomes overheated.
10. The temperature of the surface of pump is very high after use or during work, please don't touch it to avoid being burnt.
11. The instrument must not be used to create vacuum and pressure simultaneously.
12. Do not use any lubricant, which may damage the pump.
13. If the supply cord is damaged, please contact the manufacturer or your service agent for replacement to avoid hazard.
14. Please discard packing material according to local related regulations.

Unpacking

Please check if the package is complete without any damage before unpacking. When unpacking, please make sure you have all accessories that indicated on the list. If there is any problem, please keep the serial number along with packing case and contact your local distributor immediately for assistance.

Main Part Diagram

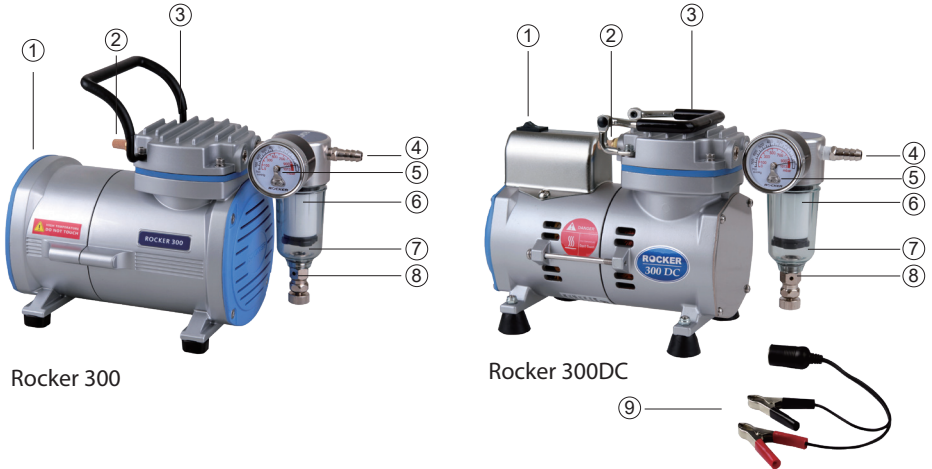

Rocker 300

Rocker 300DC

Position	Designation	Position	Designation
1	Power Switch	6	Prote™ Filter Cartridge
2	Air Outlet (Muffler)	7	Moisture Trap
3	Handle	8	Vacuum Regulator
4	Air Inlet	9	Power Cord
5	Vacuum Gauge		

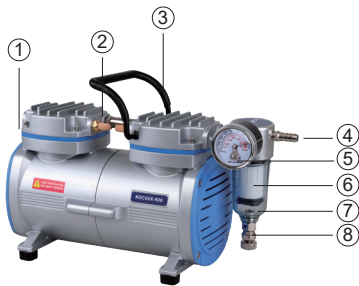

Rocker 400

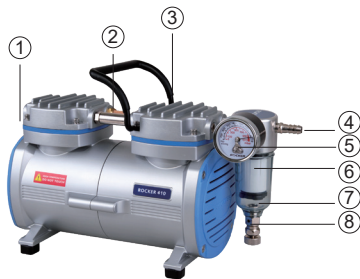

Rocker 410

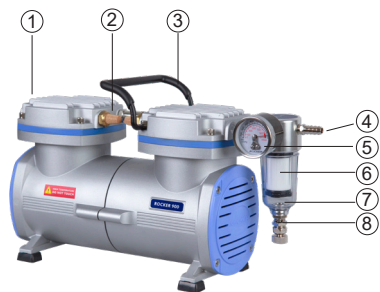

Rocker 900

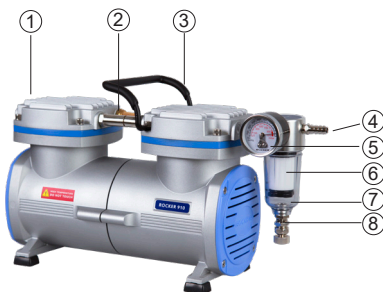

Rocker 910



Rocker 901



Rocker 911

Position	Designation	Position	Designation
1	Power Switch	5	Vacuum Gauge
2	Air Outlet (Muffler)	6	Prote™ Filter Cartridge
3	Handle	7	Moisture Trap
4	Air Inlet	8	Vacuum Regulator

* Rocker 900 / 910 is equipped with only filter cartridge, no Prote™ protection device.

Operation

• Operation

- A. Press Power Switch (1) to activate the pump after making sure all tubing are well connected.
 - A cold trap or trap bottle is recommended to connect before pump while amount of moisture exists.
- B. To setup vacuum by adjusting the vacuum regulator (8).
 - Pilot 100, vacuum controller (Cat. No. 183100-01(02)) is available for precise pressure control.
- C. Check liquid level of moisture trap (7) daily and drain the liquid when it is up to the neck of bottle.

** Warning: When pump is used for aqueous solution filtration, please ensure the liquid level of flask not exceed safety level. Failure to comply could result in serious damage to the pump and void the warranty. If it occurs,*



Filtration System Assembly Diagram

Maintenance

1. Please remove the liquid in the moisture trap after every use. If the liquid in moisture trap is more than 70%, please stop the experiment immediately to empty the liquid.
2. After finishing the experiment, please remove the liquid in the moisture trap and keep pumping the air for at least 2 minutes to withdraw the residual steam.
3. The vacuum pump is not autoclavable. Please clean the surface by pure water or 75% ethanol.
4. Valve plate(s), O-ring(s), silicone tube(s) are consumables, it is recommended to replace it on a yearly basis or as needed to ensure good operation.

• **How to reset the Prote™ protection device**

1. Remove the moisture trap (7) and filter cartridge (6) by rotating clockwise.
2. Disassemble the filter cartridge (6) to ensure the buoy is not closed.
3. Reinstall all components, filter cartridge and moisture trap back.

• **How to replace cartridge**

1. Please replace the cartridge when it becomes dirty or color-changing.
2. Please remove the moisture trap (7) by rotating it clockwise.
3. Replace the cartridge by the same way.

Troubleshooting

Problem	Reason and Solution
Failed to start	<ul style="list-style-type: none">● Loose plug → Reconnect plug to power supply.● Wrong voltage → Reconnect to power specified on name plate.● Vacuum exists → Release vacuum and restart the pump.● Switch is broken → Contact distributor for assistance.
Poor vacuum	<ul style="list-style-type: none">● Improperly vacuum setting → Adjust the vacuum regulator.● Faulty vacuum gauge → Replace a new gauge.● Air leakage → Replace or tighten the tubing and accessories that possible leaks.

Ordering Information

167300-11(22)	Rocker 300 Vacuum pump, AC110V,60Hz (AC 220V,50Hz)
167300-00	Rocker 300DC Vacuum pump, DC12V
167400-11(22)	Rocker 400 Vacuum pump, AC110V,60Hz (AC 220V,50Hz)
167410-11(22)	Rocker 410 Vacuum pump, AC110V,60Hz (AC 220V,50Hz)
167900-11(22)	Rocker 900 Vacuum pump, AC110V,60Hz (AC 220V,50Hz)
167901-11(22)	Rocker 901 Vacuum pump, AC110V,60Hz (AC 220V,50Hz)
167910-11(22)	Rocker 910 Vacuum pump, AC110V,60Hz (AC 220V,50Hz)
167911-11(22)	Rocker 911 Vacuum pump, AC110V,60Hz (AC 220V,50Hz)
183100-01(02)	Pilot 100, Vacuum Controller, AC100-240V adaptor, US plug (EU plug)
167301-06	Moisture trap / Vacuum regulator for Rocker 300 / 400 / 410
167301-07	Prote™ filter cartridge for Rocker 300 / 400 / 410
167300-42	Muffler (Air outlet) for Rocker 300 / 400 / 410
167801-06	Moisture trap / Vacuum regulator for Rocker 900 / 910
167801-07	Filter cartridge for Rocker 900 / 910 (without Prote™ overflow protection)
167600-42	Muffler (Air outlet) for Rocker 900 / 901 / 910 / 911
167300-62-1	Rocker 300 repair kit
167400-62-1	Rocker 400 repair kit
167410-62-1	Rocker 410 repair kit
167900-62	Rocker 900 repair kit
167901-62	Rocker 901 repair kit
167910-62	Rocker 910 repair kit
167911-62	Rocker 911 repair kit
167300-21	Hose barb, 1/8 PT, 5/16 in. for Rocker 300 / 300DC / 400 / 410 / 900 / 910
167300-20	Hose barb, 1/4 PT, 3/8 in. for Rocker 901 / 911
167200-38	Silicone Tube, Ø 6 x 12 mm, 1 m
180300-68	Silicone Tube, Ø 8 x 14 mm, 2 m

Rocker Scientific Co., Ltd.

Tel: +886-2-26033311 Fax: +886-2-26036622

E-mail: export@rocker.com.tw <https://www.rocker.com.tw>